



A Clip-On Oscilloscope Probe for Measuring and Viewing Current Waveforms

Although current is a fundamental quantity in electronic circuitry and accurate knowledge of it is valuable, it is a quantity that has always been rather inconvenient to measure and in at least one important case quite difficult. This is the case of alternating currents in circuits elevated from ground. Here, to use a current meter involves at best the trouble of opening the circuit, while the meter, when connected, will usually not indicate such often-needed information as the current's peak value. At the same time to measure the current waveform in such circuits with an oscilloscope has required the combination of a suitable circuit resistance to connect across and an oscilloscope with a differential input of adequate range, a combination often not available.

These problems are overcome and in addition

the general problem of measuring alternating currents is made much more convenient by a new oscilloscope probe which permits both viewing and measuring alternating currents merely by clipping the probe around the current conductor. The probe operates with the -hp- Model 150A Oscilloscope and a new plug-in amplifier to measure and display currents over an amplitude range from 1 milliamperes to 15 amperes peak-to-peak and over a frequency range from below 500 cps to 8 megacycles. In the case of sinusoidal currents, waveforms down to about 50 cps can be displayed.

Electrically, the probe consists of a wide-range current transformer with a split core which is mechanically opened and closed by flanges on the probe body in the manner proved popular in other -hp- probes. When the probe

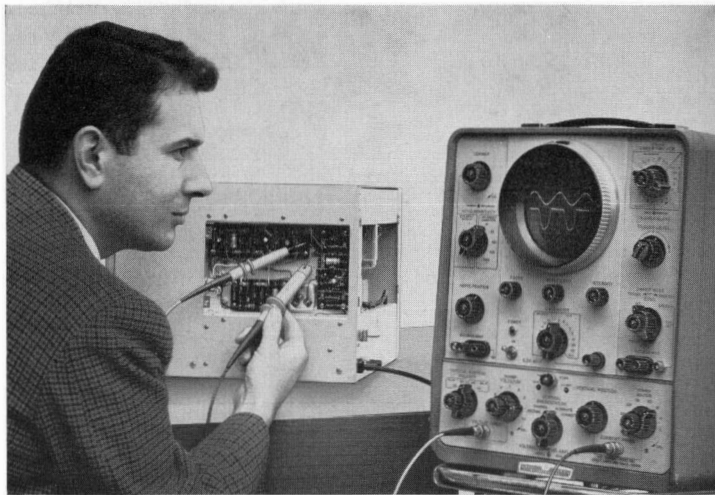

Fig. 1 (at left). New current probe and plug-in unit for Model 150A Oscilloscope enable alternating currents as small as 1 ma and up to 8 mc in frequency to be measured merely by clipping probe on conductor. Unit also includes voltage channel and dual-trace provision to permit voltage to be measured simultaneously with current.

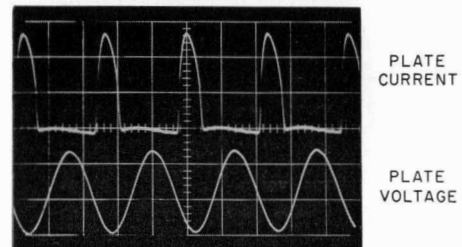

Fig. 2. Oscillogram illustrating type of display obtainable with new probe and plug-in unit. Upper trace shows plate current waveform in an oscillator circuit, while lower trace shows oscillator plate voltage.

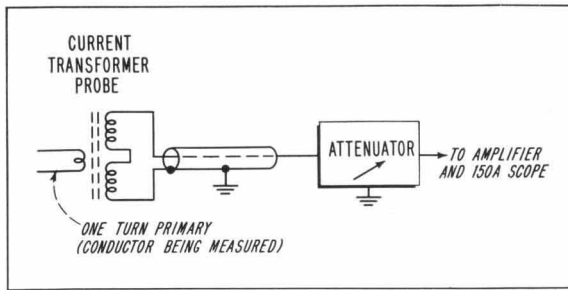
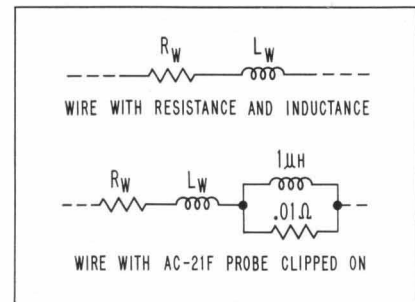

Fig. 3 (at left). Circuit arrangement of probe when clipped on conductor.

Fig. 5 (at right). Impedance reflected into measured circuit is negligible, permitting probe to be used in low-impedance circuits.



is closed around the conductor being measured, the conductor becomes a single-turn primary for the transformer. The oscilloscope then displays the waveform of the current in the conductor. The arrangement is such that very little impedance is reflected into the primary circuit, so that measurements can be made in virtually the lowest-impedance circuits without disturbance.

The plug-in amplifier associated with the probe, in addition to its current-measuring channel, also contains a voltage-measuring channel. The overall unit thus permits both current and voltage to be measured. If desired, these can be displayed simultaneously on the oscilloscope by means of a dual-trace presentation incorporated in the unit.

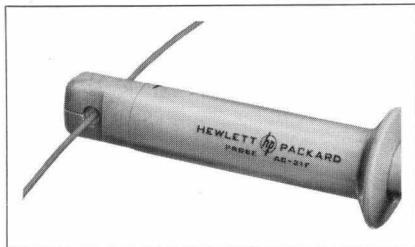

Fig. 4. Current probe clips around conductor to make measurement. Probe jaws are operated by flanges on probe body and accept conductors up to 0.175-inch O.D.

Such a dual display will then permit such quantities as impedance, admittance and phase to be determined. The voltage channel is identical to that of the -hp- Model 152A/B plug-in unit, having a maximum sensitivity of 0.05 volt/cm and a frequency range from dc to 10 megacycles.

MEASUREMENT CIRCUIT

Fig. 3 indicates the electrical arrangement of the probe. The transformer secondary is wound on a ferrite core which has magnetic properties suited to wide frequency range usage.

Magnetic and electrostatic shielding are incorporated to minimize response to fields other than that of the current being measured.

The probe operates into a broad-band amplifier of high gain such that the energy extracted from the circuit under measurement is very small—in the order of 10^{-8} watt on the most sensitive range. The loading reflected into the primary (measured) circuit is thus also very small—about 0.01 ohm—and is essentially constant with frequency. This value is shunted by an inductive component of approximately 1 microhenry, but this component is essentially shorted by the low reflected resistance. The equivalent circuit of the conductor being measured when the probe is connected is indicated in Fig. 5.

The probe also adds a slight capacitance from the conductor being measured to ground, owing to the grounded electrostatic shield in the probe. This is typically less than $1 \mu\mu\text{f}$, however, and will thus seldom be a factor in the measurement.

FREQUENCY RESPONSE

Fig. 6 shows the amplitude response of the current probe and its associated amplifier. The mid-band gain is accurate within $\pm 5\%$, which is thus the basic accuracy of the system. If desired, this value can easily be checked using the calibrator on the oscilloscope.

The high-frequency 3 db point occurs at approximately 8 megacycles, while the usable response extends to at

least 10 megacycles. Pulse-wise the system has a rise of approximately 0.045 microsecond (Fig. 7), making it usable for pulse work where the repetition rate is not too low, as discussed below.

On the low-frequency end the response of the probe circuit exclusive of the amplifier is essentially constant from high frequencies down to about 600 cps. Below this region the response of the probe begins to drop off at 6 db/octave owing to the decreasing ratio of probe transformer reactance to resistance. This drop-off has been compensated by arranging the gain of the associated amplifier to increase by 6 db/octave in this region. By itself, this compensation gives a low-frequency 3 db point in the vicinity of 50 cps and permits the probe to be used to display sine waves down to this frequency. However, the phase characteristics of a corresponding simple RL (or RC) network with a 50-cps 3-db point are such that complex waves below about 1 kc would be considerably distorted. Consequently, additional phase compensation has been provided by causing the overall response to rise a few db in the vicinity of 100 cps. This improves the phase characteristics to the point where the probe can be used with complex waves of about 500 cps and above. Fig. 8(b) demonstrates this by showing the overall response of the probe and amplifier to a 1 kc square wave, while Fig. 8(a) shows the response to the same square wave of an RL circuit with a 50 cps cut-off.

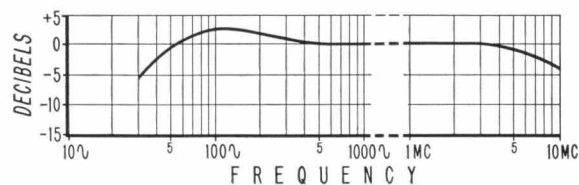

Fig. 6. Typical frequency response of current probe and amplifier as used with -hp- Model 150A Oscilloscope.

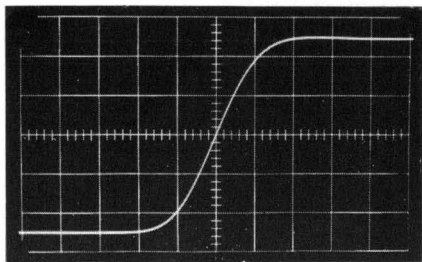
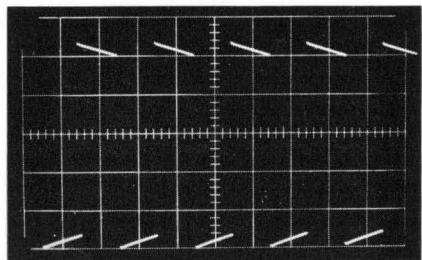

Fig. 7. Typical step response of new current probe and amplifier as used with Model 150A Oscilloscope. Sweep speed is .02 microsecond/cm, so that 10-90% rise time is approximately .045 microsecond.

CALIBRATION CHECKS

The phase characteristics of the probe-amplifier combination can easily be checked, if desired, by use of the square-wave calibrator provided on the Model 150A Oscilloscope. By shorting the calibrator terminal to ground and connecting the probe around the shorting lead, a 1 kc square wave signal is applied to the probe. If necessary, the phase characteristic of the probe can be optimized by means of a low-frequency compensation control available at the panel of the probe amplifier (Fig. 10).

The amplitude calibration can be checked simultaneously with the phase characteristic by making use of the 0.2-volt position of the calibrator. In



(a)

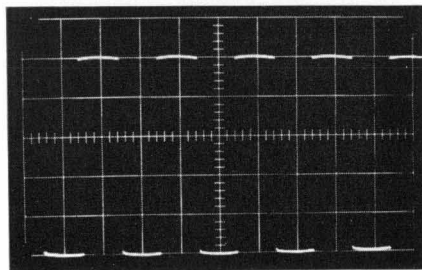

(b)

Fig. 8. Oscillograms demonstrating effect on complex waveforms of phase compensating probe amplifier, as described in text. Upper oscillogram shows response to 1 kc square wave of high-pass RL circuit with 50-cps 3-db point. Lower oscillogram shows improvement in response to same wave obtained with compensated amplifier.

this position the calibrator will deliver 5 milliamperes peak-to-peak into the shorting lead. This current can then be measured with the probe. A calibration adjustment in the form of a screwdriver-type control is located at the panel (Fig. 10).

CURRENT RATINGS

The probe has a basic sensitivity of 1 milliamperes/cm, which is extended by an attenuator on the amplifier panel in 1 - 2 - 5 - 10 - ... steps to 1 ampere/cm or 6 amperes peak-to-peak full scale. The attenuator is also provided with a 2.5:1 vernier which additionally extends this range to approximately 15 amperes peak-to-peak full scale. The probe thus covers the majority of current-measuring applications encountered in usual electronics work including power-transistor work. An arrow on the probe indicates the direction of conventional current flow (opposite to electron flow) in the conductor for an upward deflection on the oscilloscope.

Since there is a practical limitation on the size of the probe core, non-linear effects can occur with currents of high amplitude at low frequencies. Consequently, an upper limit of 1/2 ampere rms (1.4 amp peak-to-peak) per kilocycle has been established for the overall system for frequencies below 20 kc (Fig. 9). This implies that the current should not exceed 5 amperes rms at 10 kc, 50 milliamperes at 100 cps, etc. This limitation is conservative, representing the point at which phase error begins to distort the shape of a square wave. With sine waves, where amplitude accuracy is usually more important than small phase errors, it is permissible to exceed this limitation by a factor of 4 and handle currents of 2 amperes rms (5.65 amp peak-to-peak) per kilocycle.

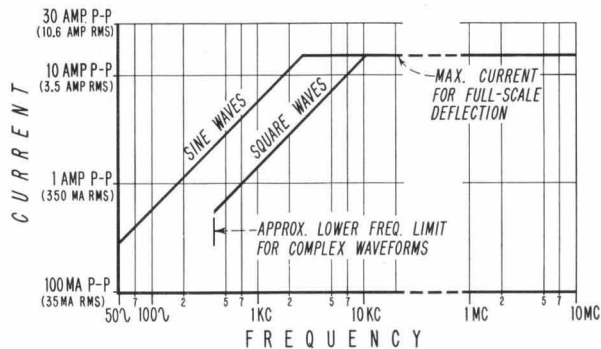

Fig. 9. Rating curves for -hp AC-21F current-measuring probe.

DC EFFECT

The effect of direct current in the circuit being measured in the amounts usually found in electronic circuits has little effect on the measurement. A direct current of 1/2 ampere can be present in the measured circuit without noticeable effect on any current range of the system. Application or removal of unusually large dc currents may cause a temporary increase in probe inductance, but this will disappear in less than a minute.

HIGHER SENSITIVITIES

Since the probe measures current values by measuring the signal induced in the probe coil by the current flowing in the conductor, the sensitivity of the measurements can be increased by increasing the number of turns acting as the primary. The increase in sensitivity will be proportional to the number of turns, i.e., 4 turns will increase the basic sensitivity from 1 ma/cm to 1/4 ma/cm.

Increasing the number of turns in the primary will also increase the impedance reflected into the primary in proportion to the square of the number of primary turns. In high-frequency work it should be noted that the turns themselves will also add inductance to the primary circuit.

CURRENT BALANCING AND SUMMING

Besides measuring and viewing single current waveforms, the probe is often useful in cases where it is desirable to balance currents such as in push-pull amplifiers. By clipping the probe around two conductors simultaneously, such as around the two cathode leads of the amplifier, the oscilloscope will display the difference between the two currents. Circuit adjustments can then be made to balance the signal currents to a high degree.

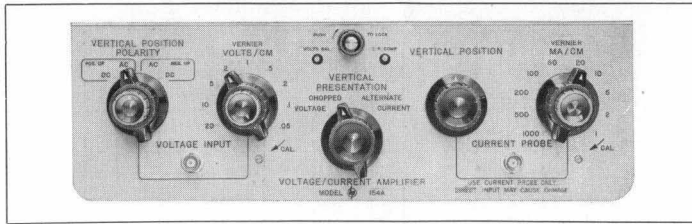

Fig. 10. Panel view of *hp-Model 154A Voltage/Current Plug-in Amplifier*.

MAGNETIC SEARCHING

It is also feasible to use the probe to search out the direction and magnitude of ac magnetic fields. This can be done by fashioning a single shorted-turn coil for use with the probe. Magnetic fields will induce currents in this coil which will be indicated by the probe and oscilloscope, permitting the direction and strength of the field to be determined.

EXTERNAL FIELDS

To minimize the effect of external magnetic fields, the probe has been carefully shielded and symmetrical construction has been used, but strong fields such as may be encountered in the vicinity of a power transformer or electric motor will link the probe sufficiently to cause a reading. The effect that such a field may have on the measurement can be determined by holding the probe with its jaws closed in the region in which a measurement is to be made. In cases where the reading may be excessive for the measurement, the measurement can often be made on another portion of the conductor farther removed from the source of the field.

Dc magnetic fields such as are normally encountered from typical direct currents in electronic circuits and from the earth's field have no observable effect on measurements with the probe.

INSULATION

While the exterior surfaces of the probe are formed from insulating materials so that there is no danger to the operator from reasonable voltages, the mating edges of the probe jaws are part of a metallic shield and are connected to ground. To avoid grounding the circuit being measured, then, it is necessary that the conductor being measured be insulated. In the case of bare conductors this can usually be accomplished without breaking the circuit by slipping a short length of split spaghetti over the conductor or by wrapping the conductor with a piece of insulating tape.

VOLTAGE CHANNEL

In order to make the system as flexible as possible, and in fact to add to its usefulness by permitting a dual display, the plug-in unit has been arranged to include a voltage-measuring channel as well as the current-measuring channel. This not only enables voltage waveforms to be compared with current waveforms but permits impedance, admittance and phase to be determined.

The voltage-measuring channel has a bandwidth from dc to 10 megacycles and a sensitivity range extending from 0.05 volt/cm to a maximum of 300 volts peak-to-peak full scale. Its input impedance is 1 megohm shunted by approximately 30 $\mu\mu\text{f}$, which can be increased to 10 megohms shunted by 10 $\mu\mu\text{f}$ with the 10:1 division AC-21A probe supplied with the Model 150A. The AC-21C 50:1 division probe can also be used to increase the input im-

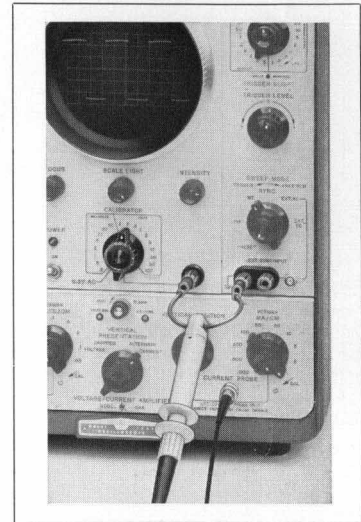

Fig. 11. *Amplitude and phase response of probe and amplifier can easily be checked using calibrator on Model 150A Oscilloscope.*

pedance to 9 megohms shunted by only 2.5 $\mu\mu\text{f}$.

Like the current channel, the voltage channel has a 5% accuracy rating. It also has a polarity-inverting switch, while in the current channel current direction is obtained from the orientation of the current probe.

—Robert R. Wilke

SPECIFICATIONS

-hp- MODEL 154A

VOLTAGE/CURRENT AMPLIFIER WITH AC-21F CLIP-ON PROBE

When plugged into -hp- Model 150A Oscilloscope

CURRENT CHANNEL

Band Pass: 50 cps to 8 mc.

Sensitivity: 10 calibrated ranges, 1 ma/cm to 1000 ma/cm in a 1, 2, 5, 10 sequence. Accuracy $\pm 5\%$ with vernier in "cal" position. Vernier provides continuous control between calibrated steps and extends 1000 ma/cm range to at least 2500 ma/cm.

Maximum AC Current: 10 amperes rms 20 kc and above. Below 20 kc core non-linearity reduces current capability proportional to frequency. For example, maximum current is 5 amps rms at 10 kc and $\frac{1}{2}$ amp at 1 kc.

Maximum DC Current: Direct current up to $\frac{1}{2}$ amp has no appreciable effect.

Calibration: Calibrate at 5 ma with short circuited 150A calibrator output on the 0.2v position.

Input Impedance: (Impedance added to test circuit by probe) approx. 0.01 ohm shunted by 1 μhenry .

VOLTAGE CHANNEL

Band Pass: DC Coupled: dc to 10 mc, 0.035 μsec rise time. AC Coupled: 2 cps to 10 mc, 0.035 μsec rise time.

Sensitivity: 9 calibrated ranges, 0.05 v/cm to 20 v/cm in a 1, 2, 5, 10 sequence. Accuracy $\pm 5\%$ with vernier in cal. Vernier provides continuous control between steps and extends 20 v/cm range to at least 50 v/cm.

Input Impedance: Approx. 1 megohm (nominal) shunted by 30 $\mu\mu\text{f}$.

GENERAL

Vertical Presentation: (1) Either voltage or current signal continuously or (2) voltage and current signals sampled at 100 kc or on alternate traces.

Vertical Position: Each channel individually adjustable.

Power: Supplied by Model 150A Oscilloscope.

Weight: Net 5 lbs., shipping 10 lbs.

Accessories Available: AC-21A Probe (10:1 voltage division), \$25.00; specify gray or black lead. AC-21C Probe (50:1 voltage division), \$25.00; specify gray or black lead.

Price: Model 154A Voltage/Current Amplifier with AC-21F Clip-On Probe: \$430.00.

Prices f.o.b. Palo Alto, California
Data Subject to Change Without Notice